

Isometric View

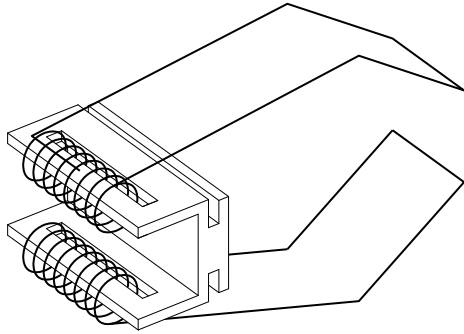

End View

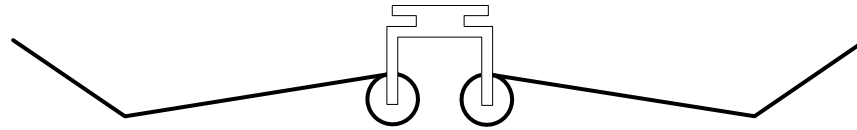

- 1. Measure area where LLED8350-WRCR will be installed.**
RECOMMENDATION: Use chalk line to ensure a straight installation.

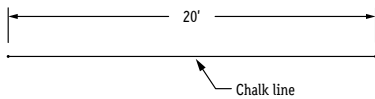

- 2. Mark location where mounting clips will be installed.**
TIP: Quantity of mounting clips = quantity of fixture +1.
Use a mounting clip at the joint between two fixtures.

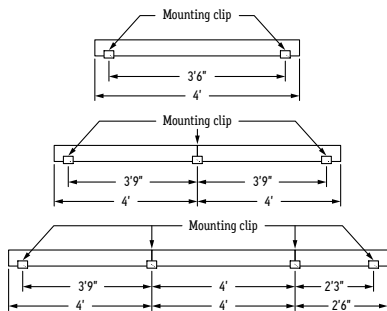

- 3. Slide mounting clips into channel underneath extrusion.**

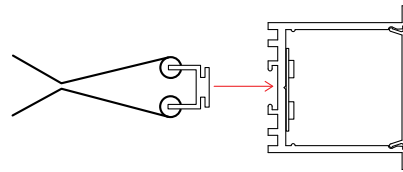

- 4. Pinch spring-loaded arms together and insert into pre-cut recess.**

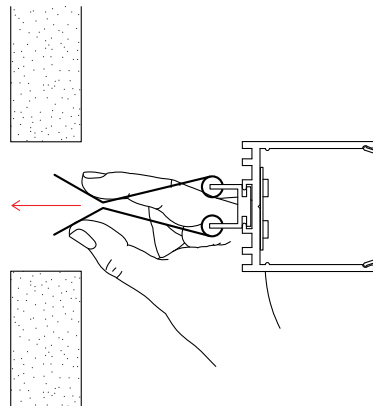

- 5. Release spring-loaded arms, allowing the spring's tension to pull extrusion into place.**

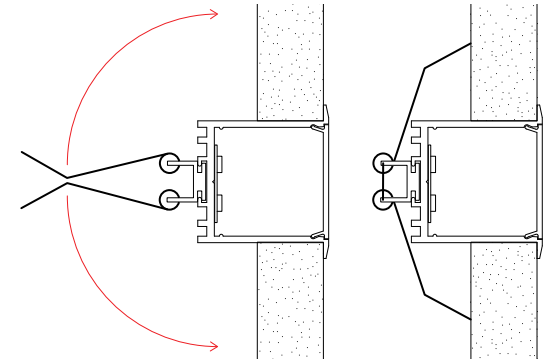

Assembled End View

